

THE KENNEDY CIRCA 2

MAN ON CIRCUIT:

THE CIRCA OF

WORLD 2 W24

FLORIDA

Rosemary Ginn Sawyer, PE
and Denise Couey Brown, PE

October 2016



The Mobile Bay Watershed Environmental Resources



The Mobile Bay Watershed encompasses 65% of the land area of the state of Alabama, along with portions of Mississippi, Georgia and Tennessee.

The Watershed is a vast network of over 250 separate waterways, including rivers, bays, creeks, bayous, lakes, cutoffs, branches, and sloughs.

This Watershed is the 4th largest drainage basin in North America by flow volume and 1st in biodiversity.

Mobile is a Waterfront City



Mobile is a Historic City



Mobile is a City with Diverse Environmental Resources



The Mobile Bay Watershed is home to both salt water and fresh water habitats.

The Mobile River Delta and Mobile River Basin provide a strong foundation for recreational opportunities in the Mobile region.



Mobile is America's Rainiest City



City Ranking 2013	Annual Rainfall (in)	Annual Rain Days
1. Mobile	67	59 (2013)
2. Pensacola	65	56 (2013)
3. New Orleans	64	59 (2013)
41. Seattle	33	149 (avg.)
42. Portland	26	154 (avg.)

Mobile is a City waging a war on Litter. We Needed to Make a Change!



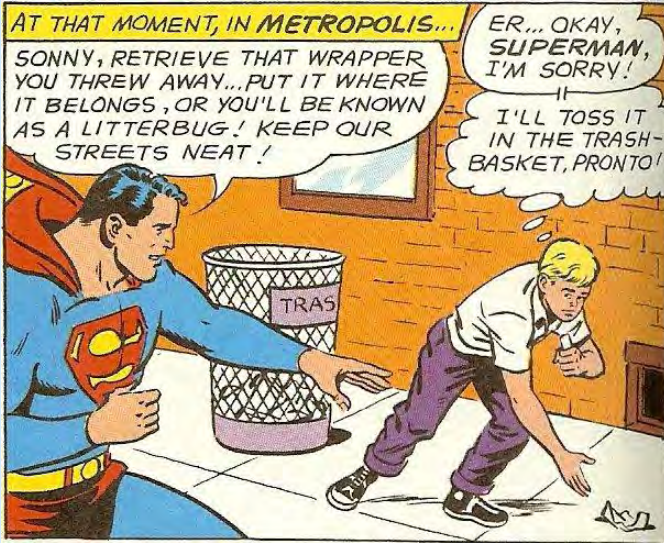

www.robertxgillis.com

This is why we
need to keep litter
out of our waterways!

LITTER LASTS THIS LONG

LITTER LASTS THIS LONG

CIGARETTE BUTTS.....	1-5 YEARS
ALUMINUM CANS.....	80-100 YEARS
ORANGE PEELS.....	UP TO 2 YEARS
PLASTIC BAGS.....	10-20 YEARS
GLASS BOTTLES.....	1 MILLION YEARS
TIN CANS.....	50 YEARS
WOOL SOCKS.....	1-5 YEARS
PLASTIC BOTTLES.....	INDEFINITELY

theind.com



Water Quality

EPA's Clean Water Act requires that a Municipal Separate Storm Sewer System (MS4) operate under a NPDES Permit.

The City of Mobile's MS4 drains rainwater and all runoff into natural waterways. Litter on the streets goes through the storm drains into these waterways as "floatables" and is a major source of water pollution.

How are we combatting this litter issue?

We have a game plan.



WHEN IT RAINS
IT DRAINS



001 09116 11911

- ❖ Developed and Passed Ordinances
- ❖ Enforcing the Ordinances
- ❖ Educating the Public
- ❖ Preventing the Litter from Reaching the Waterways
- ❖ Cleaning-up the Litter that does

CHALLENGES?

Maintain Mobile
Clean Choices. Clean Water



CITIZEN ORDINANCE

Chapter 25 – Garbage, Litter & Lot Maintenance

➤ Prohibits

- ❖ Littering
- ❖ Hauling Debris without proper cover
- ❖ Dumping trash or garbage improperly
- ❖ Sweeping or blowing litter, yard clippings, trash or leaves into the streets and drains
- ❖ Placing trash on medians or sidewalks
- ❖ Placing trash out more than 48 hours prior to scheduled pick-up

➤ Requires

- ❖ Furnishing & maintaining of receptacles
- ❖ Fines plus court costs for violations

CITIZEN ORDINANCE

Chapter 25 – Garbage, Litter & Lot Maintenance

➤ Amendments

- ❖ All dumpsters are required to be labeled with placard listing responsible party and contact information.
- ❖ After 2 violations for a dumpster overflowing, you are required to enclose the dumpster.
- ❖ Property owner and occupant can be fined for violations of Litter Ordinance – includes Rights-of-Way and sidewalk adjacent to the property.
- ❖ Failure to keep the property clean is a violation of the litter ordinance.
- ❖ Property owners, tenants, AND occupants are responsible for keeping parking lots clean.
- ❖ Fine Structure revised:
 - \$250 plus court costs for Knowing Violations of ordinance.
 - \$100 plus court costs for other violations.

2018 ORDINANCE

Chapter 54, Article V – Signs in Public Rights-Of-Way

- Amended to only allow Signs on Weekend
 - ❖ *From 4pm Friday to 8am Monday*
 - ❖ *Subject to be fine if not removed Monday am*

- *Only temporary signs - 24" x 24" or smaller , no higher than 48" off of the ground*
 - ❖ *Such as yard sale sign, real estate signs, political signs, event signs, etc.*
 - ❖ *Cannot interfere with line of sight visibility of oncoming traffic*

- *Never allowed attached to utility poles or trees*

- *Never allowed in median*



STORM WATER MANAGEMENT

Chapter 17 – Storm Water Management & Flood Control (as it pertains to Litter)

- Works with the Litter and Sign Ordinances to prevent & reduce the degradation and obstruction of waterways
- ❖ Interdepartmental SOP ~ lead department is assigned
- ❖ Prohibits Illicit discharges and pollutants, including litter
- ❖ Fines of \$60 - \$150 plus court costs
- ❖ Third offense ~ penalty determined by Judge
- ❖ Can be fined for each day violation continues

201111 11961 01111916

Chapter 17 – Storm Water Management & Flood Control (as it pertains to Litter/Water Quality)

- “Dumpster Juice”
 - ❖ Effective May, 2009, Dumpsters and Car Washes were required tie to the sanitary sewer system on new developments or re-developments .
 - ❖ Effective December, 2012, the Zoning Ordinance was amended to reflect the “Dumpster Juice” requirement for dumpsters on Planning Commission applications.



SAMUEL L. JONES
MAYOR

May 13, 2009

RE: Engineering Department Policy Letter

To Whom It May Concern:

As a point of clarification, all dumpster pads and car wash discharges must tie to a sanitary sewer system, and not the storm sewer system. (This is required regardless of whether or not the discharge is conveyed through an oil water separator or other means of treatment.) The tie to the sanitary sewer system needs to be shown on the site plan submitted with building and/or land disturbance submittals.

The City does not intend to place an additional burden to project development, but this is necessary to keep the City's permitting practices in compliance with its Municipal Separate Storm Water Permit (MS4) with the Alabama Department of Environmental Management (ADEM).

In case you were not aware, the City of Mobile is required to have a MS4 permit administered by ADEM, as part of the Environmental Protection Agency's (EPA) Phase I and II National Pollution Discharge Elimination System (NPDES) Storm Water Programs.

Sincerely,

Nick Amberger, PE
City Engineer/Deputy Director Public Works

cc: John Bell
Ray Richardson

CITY OF MOBILE
ENGINEERING DEPARTMENT

OFFICE OF THE CITY COUNCIL
COUNCILMEMBERS
REGGIE COVELAND, SR.
PRESIDENT-DISTRICT 1
FREDRICK D. RICHARDSON, JR.
VICE PRESIDENT-DISTRICT 1
WILLIAM C. CARROLL, JR.
DISTRICT 2
CLYNTON L. JOHNSON
DISTRICT 3
JOHN C. WILLIAMS
DISTRICT 4
CONNIE HUDSON
DISTRICT 4
GINA GREGORY
DISTRICT 7
CITY CLERK
LEIA C. LAMBERT

P.O. BOX 1827 - MOBILE, ALABAMA 36633-1827

STORM WATER MANAGEMENT

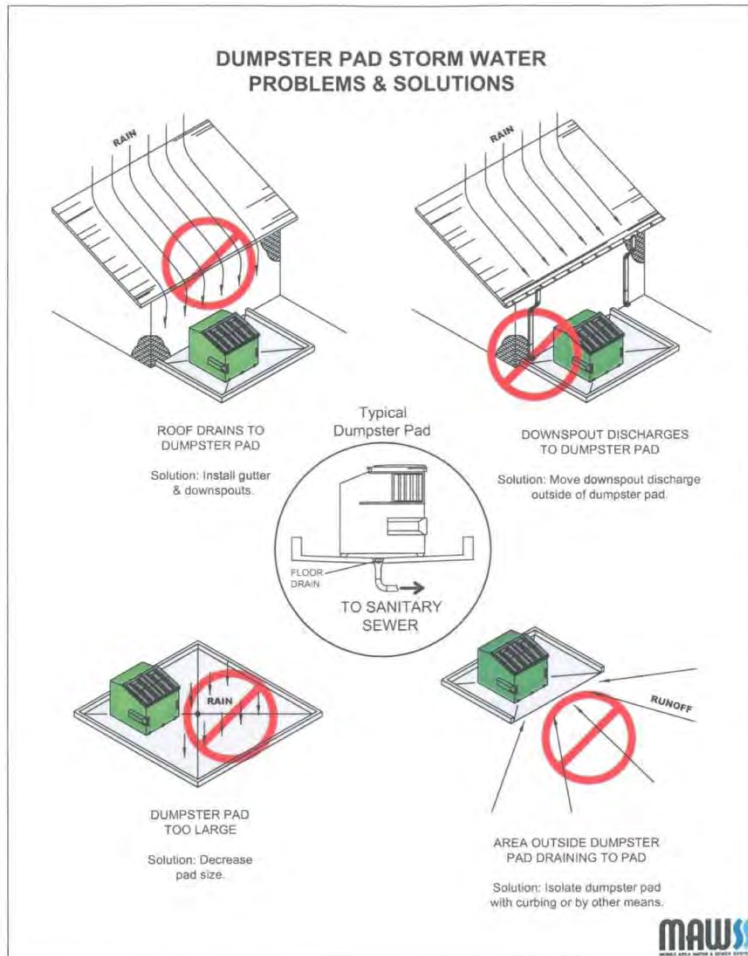

- ❖ Minimizing stormwater into the Sanitary Sewer with the “Dumpster Juice” Requirement
- ❖ Partnership with MAWSS

ΕΠΙΧΕΙΡΗΣΙΑΣ & ΚΕΝΤΡΙΚΗΣ

Maintain Mobile
Clean Choices. Clean Water



LEGISLATION & ENFORCEMENT

- ❖ Enforcing the Ordinances
- ❖ Municipal Enforcement
 - Additional Inspectors
 - Investigate SROs
 - Routine Patrols
 - Issue Tickets
- ❖ Police Department
- ❖ Litterbug Hotline
- ❖ 311 System - SROs
- ❖ Litter Hotspot Map

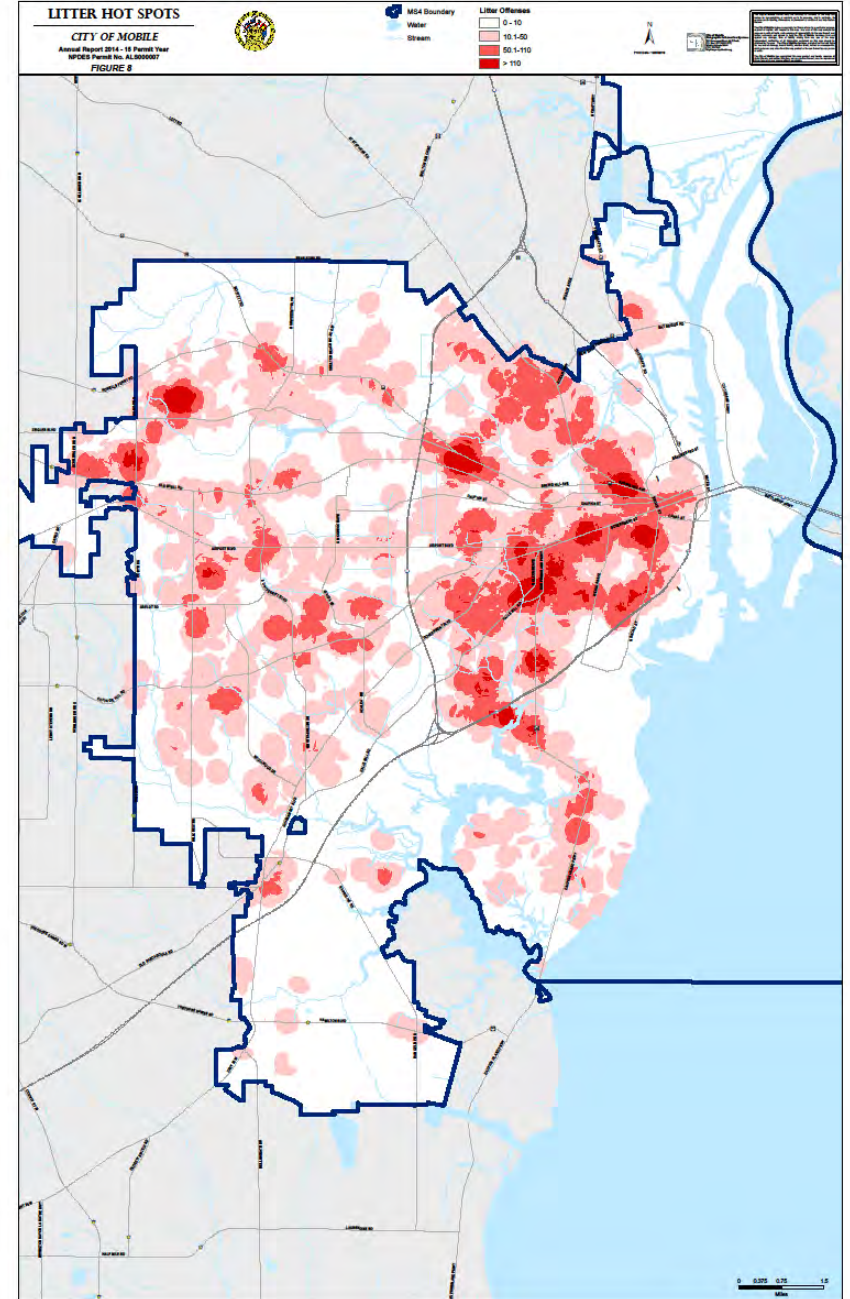

ENLARGED CONTENT

- ❖ Enlarged the tickets and enhanced the content to include photographic evidence of the litter ordinance violation;

Bubba's Convenience Store
Name of Business/Entity/Owner
1234 Hunter Rd
Local Business Address
Good 'ole Boys, llc, 1 Park Place, NY, NY
Address of Corporate Business (if different)
251-BR-549 945-RB-152
Phone Number (Local and Corporate)
Dukes of Hazard
Authorized Agent



102025

CITY OF MOBILE MUNICIPAL OFFENSE TICKET

CITY OF MOBILE, MOBILE COUNTY, ALABAMA

The undersigned, being duly sworn, deposes and says that he has probable cause to believe and does believe that the person herein named committed the offense hereinafter set forth on or about: MONTH DAY YEAR AT APPROX. TIME A.M. P.M. M.T.

COMPLAINT AND AFFIDAVIT

FIRST NAME MIDDLE/MAIDEN LAST
 ADDRESS STREET
 CITY STATE ZIP CODE
 STATE DRIVER'S LICENSE NUMBER SEX RACE
 BIRTHDATE MO DAY YEAR VEHICLE TAG NUMBER STATE YEAR
 VEHICLE DESCRIPTION (YEAR, MAKE, TYPE) NAME ADDRESS OWNER EMPLOYER
 SOCIAL SECURITY NUMBER
 Did offender violate an ordinance with the city limits or public jurisdiction of Mobile, Alabama at or near the following location (describe below):
 In violation of Municipal Ordinance or City Code Section _____ more particularly described as:
 DESCRIPTION OF OFFENSE section below (Use description of offense below):
 OFFICIAL SIGNATURE Sworn to and acknowledged before me this date MONTH DAY YEAR
 DEPARTMENT SIGNATURE AND TITLE

COURT APPEARANCE INFORMATION

IN THE MUNICIPAL COURT OF THE CITY OF MOBILE, MOBILE COUNTY, ALABAMA
 City of Mobile v. _____ (Defendant)
 TRIAL DATE MONTH DAY YEAR TIME A.M. P.M. 205 Government Street
 Mobile, AL 36652

NOTICE TO THE ABOVE NAMED DEFENDANT:

YOU ARE CHARGED WITH THE OFFENSE _____ IN ACCORDANCE WITH THE RULES OF JUDICIAL ADMINISTRATION, YOU MAY ELECT TO PLEAD GUILTY TO THIS OFFENSE BEFORE A MAGISTRATE AND PAY A FINE OF \$ _____ WHICH INCLUDES COURT COSTS. **A WARRANT WILL BE ISSUED AFTER THE ABOVE DATE IF YOU HAVE NOT APPEARED PERSONALLY AND PAID SAID FINE AND COSTS OF COURT.**

DESCRIPTION OF OFFENSE

MUNICIPAL OFFICIAL'S REMARKS: _____

White - Court Canary - Municipal Official Pink - Detained

FOR GUILTY PLEA: SEE REVERSE

ATTORNEY

- ❖ Required dumpster to be labeled with responsible party in control of dumpster



2000622 - CIRCUIT ENCLOSURE

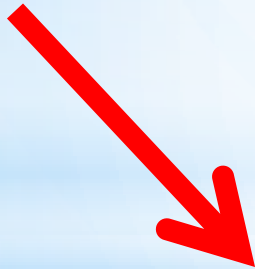

Public Utilities & Education



PUBLIC OUTREACH

- ❖ Keep Mobile Beautiful
 - Participates in local events
 - Classroom presentations
 - Recycling
 - Equipment for Clean-up events
- ❖ Partnered with ALDOT for a local clean-up and lunch and learn
- ❖ Partnerships with MBNEP, ACF and community environmental groups
- ❖ Website www.stormwatermobile.org
- ❖ Brochures distributed
- ❖ Public Service Announcements – Clean Water Future
- ❖ High School student forum
- ❖ Meetings and presentations

FINAL CLEAN-UP EVENT?



- ❖ 82 Events last year with KMB supplying equipment
- ❖ One Clean Mobile Event
 - Partnered with ALDOT
 - Nearly 80 participants
 - Collected approximately (20) 30-gallon bags



Spring Hill Avenue
Litter Cleanup

You're invited to the Spring Hill Avenue Litter Cleanup!

Who: City of Mobile and ALDOT
When: Saturday, April 16th, 8:00 AM to 11:00 AM
Where: Mobile Infirmary, Medical Office Building
1720 Spring Hill Avenue, Mobile, AL
Contact: stormwater@cityofmobile.org



#onecleanmobile



#OneCleanMobile





HIGH SCHOOL GRADUATE LEADERS

- ❖ September 20, 2016
- ❖ Litter and Stormwater Awareness

- ❖ 22 Students participated from 10th & 11th grades
- ❖ 8 area High Schools
- ❖ Two hours of discussion and feedback on litter issues and methods to reach high school students



C1922LO0W IIA01A6U6U



- ❖ Outreach coordinator visits schools weekly to discuss litter
- ❖ Reached over 9000 students last year
- ❖ Elementary children sign a pledge to not litter

#OneCleanMobile

CATCH BASIN CLEANING

- ❖ Over 35,000 catch basins in City
- ❖ Minimum of 5% of those cleaned each year
- ❖ Removed 3990 CY of debris last year



BLGAGUCIUU

Maintain Mobile
Clean Choices. Clean Water



2016 2M66DU8

- ❖ Over 12,700 lbs. of material collected last year
- ❖ Downtown streets swept weekly
- ❖ Four (4) sweepers



WORLD CLASS

- ❖ Over 20 parades roll through downtown Mobile each year



CATCH BASIN SCREENS



The Party that Goes Down the Drain

- ❖ 69 catch basin screens installed along Mardi Gras Parade Routes

- ❖ As of early October, 137 total screens had been installed City-wide.



2009 9 11 10 15 AM



???



ACF's Eco-Team

WWD KECACILUS CEURGI

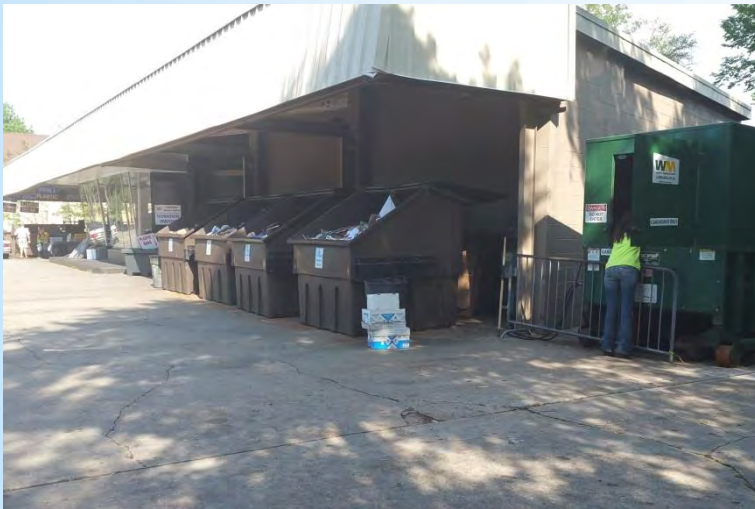

TYPICAL ITEMS

- ❖ Paper & cardboard
- ❖ Plastics – 1 & 2
- ❖ Glass
- ❖ Steel & Aluminum cans



KWD KECACILUS CEURGI

LESS COMMON

- ❖ Plastic grocery bags
- ❖ Used motor oil & filters
- ❖ Used cooking oil
- ❖ Batteries
- ❖ Toner cartridges

UNUSUAL ITEMS

- ❖ Christmas trees
- ❖ Mardi Gras Beads
- ❖ Packing Styrofoam
- ❖ Christmas lights
- ❖ Bubble Wrap
- ❖ Fluorescent light bulbs
- ❖ Flags



CONSTRUCTION

LID First Flush Requirement for New Construction and Redevelopment

Tier 1 Sites - 1 acre or greater

Focus on
Capture
of Floatables

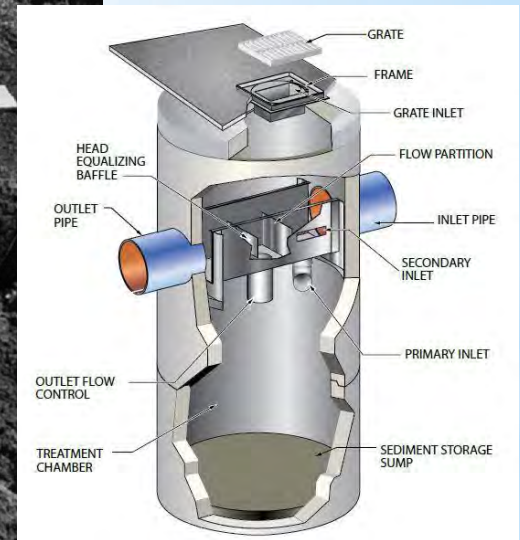

Example: VortSentry HS Units
used on MAA Taxiway Project

PIPING CAPABLE DEVICES?

- ❖ Each of 7 City Council District receiving devices
- ❖ Locations selected based on Litter Hot Spot Map

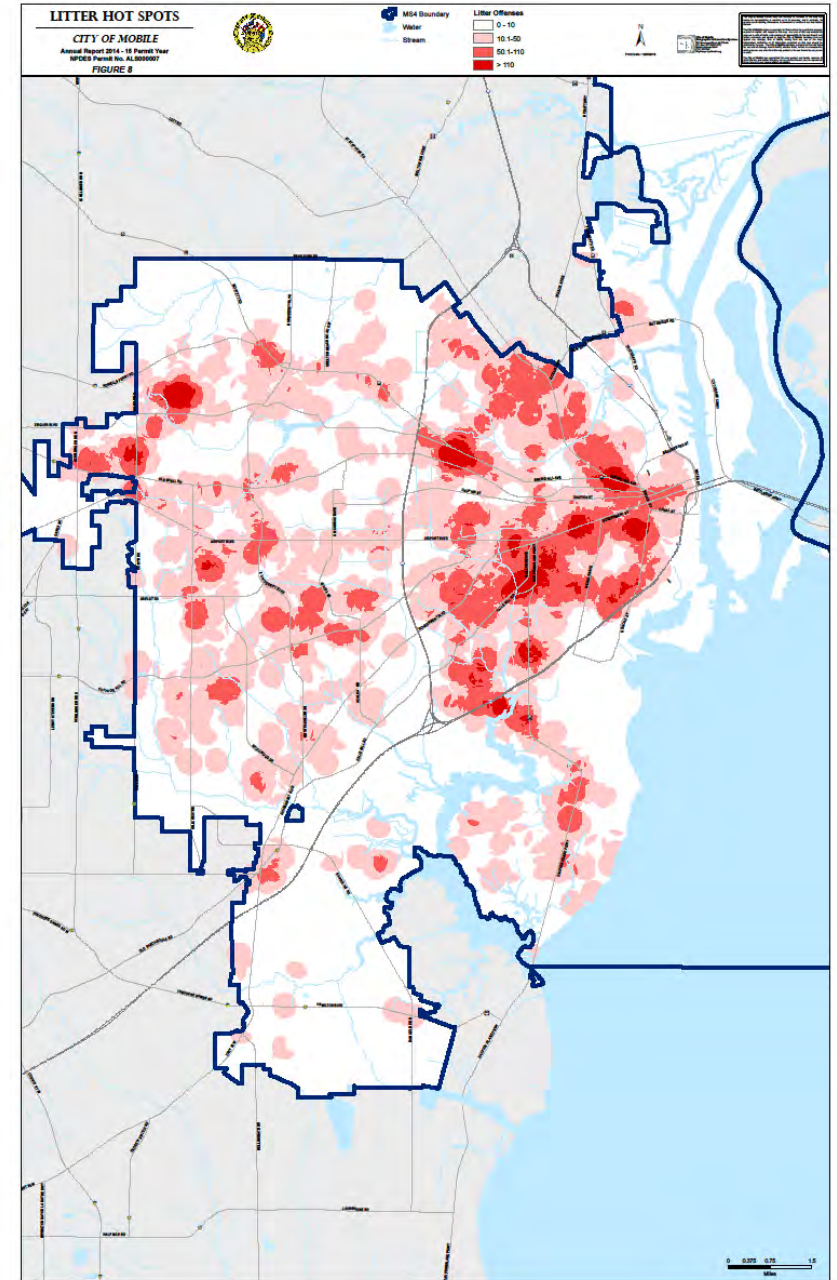

ΚΕΛΗΓΕΙΡΓΙΟΥ & - CIGRA-ND EIIOLC?

Maintain Mobile
Clean Choices. Clean Water





Photo credit - Gulf Equipment

ESLAVA CREEK

Site Selection & Permitting

- ❖ Located on Eslava Creek @ N. McVay Dr.
- ❖ Arduous process to select & permit location
- ❖ Purchased adjacent land for access



CIRCUIT 119D



Inspection & Maintenance

- ❖ Emptied by loader after large rainfall or when $\frac{1}{4}$ CY of floatables are present
- ❖ Track & estimate amount of litter removed

- ❖ Inspected every few days & after a 2-year, 24 hour rain event (approx. 5.67")



Patrol Dog

- ❖ Two Litter Boats
 - Carolina Skiff – launched December 2015
 - Jon boat
- ❖ Patrol Dog River, Three Mile Creek and One Mile Creek



GIUGL D09C2

- ❖ Track & estimate amount of litter removed
- ❖ Avoid dangerous snakes & gators



PIPER COLLECTION - BULK?



- ❖ Litter picked up before mowing
- ❖ App used for contractor mowing to track issues
- ❖ Inmates and those needing service hours through court system are used to pick up litter in the City maintained ROW

Litter

Mobile's Efforts are Making a Difference!



Rosemary Ginn Sawyer, PE, CFM, CPMSM

sawyer@cityofmobile.org

(251) 208-7581

Denise Couey Brown, PE

denise.brown@cityofmobile.org

(251) 208-7529

City of Mobile Storm Water Webpage

www.stormwatermobile.org





Questions?